

MVCweb Control System

HONEYWELL EXCEL 5000 OPEN SYSTEM

PRODUCT DATA



GENERAL

MVCweb is Honeywell's Ethernet-based, freely-programmable Building Automation controller offering a combination of BACnet IP, BACnet MS/TP, and LONWORKS® communication.

It demonstrates Honeywell's full commitment to reducing total installed cost and total building lifecycle cost for building investors and building operators.

MVCweb incorporates the two major open standards in today's building industry: BACnet® and LONWORKS®.

As a native BACnet® Building Controller (B-BC), MVCweb integrates into any 3rd-party BACnet® system with low and predictable effort.

Furthermore, MVCweb (in combination with the IF-LON) is a full LONWORKS® controller. This gives the benefit of making use of the LONWORKS® product portfolios of Honeywell and 3rd-party manufacturers.

MVCweb can host a huge variety of building management applications, be it traditional heating, ventilation, and air conditioning (HVAC) applications, energy management functions, including optimum start/stop, night purge, and maximum load demand, supervisory functions for lighting, sun-blind, heat and energy metering and many other applications.

By virtue of its "peer-to-peer" concept, MVCweb is not dependent upon the availability of superordinate centrals or application network controllers.

MVCweb seamlessly integrates into Honeywell's EBI and SymmetrE® front-ends.

3RD-PARTY SOFTWARE LICENSES

This product contains software provided by third parties. See also MVCweb Controller – Third-Party Software Licenses (Product Literature No.: EN2B-0400GE51).

FEATURES

- **Reduced the total installed cost:**
Existing standard Ethernet/LAN infrastructure is used for communication between MVCweb controllers, 3rd-party BACnet® controllers, and BACnet® front-ends. Costs are further reduced by the flexible and optional use of onboard I/Os and Panel Bus I/Os.
- **Universal operation:**
Via Internet browser, MVCweb can be operated from any place, from any PC connected to the (MVCweb) network! An integrated web-server allows local and remote operation by standard browsers.

NETWORK SECURITY

When operating MVCweb in IP networks, either private (e.g., VPN) networks must be used or protection against the open Internet (e.g., with external firewalls) must be ensured. See "Network Security" on pg. 6.

- **Reduced cost for service, operation and maintenance:**
Maintenance or upgrade of Operator Interface Software is superfluous because it resides in MVCweb, itself (single-source principle).
- **Vendor independence:**
Communication is based on the following international standards: BACnet/IP (ISO 16484-5); BACnet MS/TP (ISO 16484-5); LONWORKS (ISO 14908); Modbus RTU Master; M-Bus (EN 1434-3).
- **Trending:** 100 datapoints can be trended.
- **Fast application control:**
Four selectable control loop priorities (multitasking), selectable control loop cycle times, and event-driven switching tables allow for tailored and highly effective applications control.
- **Reliable control performance:**
Embedded LINUX ensures reliable, independent, and secure operation, especially for systems with Internet access.
- **Embedded e-mail/SMS alarming:**
Configurable e-mail alarming options allow alarms to be sent (via network or Internet-DSL connection) to e-mail accounts and thus also to mobile phones.
- **Honeywell CARE tool:**
Allows re-use of existing applications and application macros, enables highly effective application generation, and supports online application debugging.
- **Flexible mounting options:** Mounting onto wall or onto panel back wall, into panel door, onto panel rail, and into sub-panels (fuse boxes).

OPERATOR INTERFACE

MVCweb is operated via a standard browser. By default, an integrated web-server provides all operation pages for a full browser-based operation.

Through the consequent use of software standards, any PC platform can be used as an operator interface (client), including laptops, desktops PCs, or touch screen PCs for direct flush mounting into electrical panel doors (IP65).

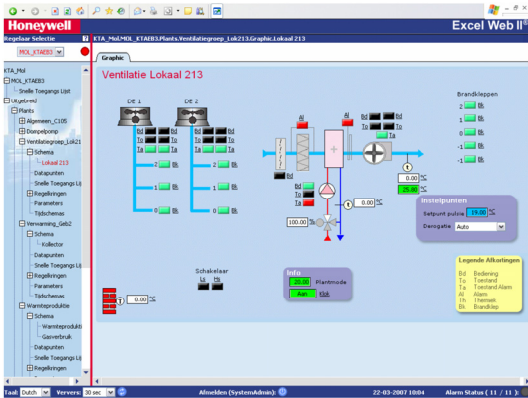

Fig. 1. MVCweb "Homepage" Example

Programming

MVCweb is freely programmable using the graphic CARE Engineering Tool and is thus ideal for all Building Control and Building Management tasks.

Password Protection

MVCweb allows the definition of up to 6 user levels. Each user level can be assigned different read and write rights. Several users with individual passwords can be defined for each user level.

COMMUNICATION PROTOCOLS

BACnet/IP - ISO 16484-5 – EN 13321-1

Communication with other MVCweb controllers, 3rd-party BACnet devices, Honeywell Enterprise Buildings Integrator™ and SymmetrE front-ends, and with 3rd-party BACnet front-ends is based on the international BACnet Protocol.

MVCweb conforms to the BACnet Building Controller (B-BC) profile.

For details on the BACnet Interoperability, see the MVCweb Protocol Implementation Conformance Statement (PICS) (Product Literature No.: EN0B-0716GE51).

BACnet MS/TP – ISO 16484-5 and EN 13321-1

Communication with other BACnet controllers (Honeywell and 3rd-party) is based on the international BACnet Protocol.

Optionally, one or both of the onboard RS485 interfaces can be used for communication via BACnet MS/TP.

LonTalk® - ISO 14908

Optionally, communication with physical I/O modules, with room and zone controllers, and with Honeywell Excel 50 and Excel 800 controllers can utilize LonTalk.

With the IF-LON, a Free Topology Transceiver (FTT-10A or FT-X1) allows a communication speed of 78 Kbaud.

Max. cable lengths are 320 m to 2,200 m, depending upon the given wiring topology.

By default, the IF-LON comprises the LonMark® node object, plus application-specific LONWORKS objects.

Modbus RTU Master

Optionally, either of the two onboard RS485 interfaces (but not both simultaneously) can be used for communication via Modbus RTU.

Please refer to the MVCweb – Installation & Commissioning Instructions (Product Literature No.: EN1B-0567GE51) for details.

M-Bus – EN 1434-3

Optionally, M-Bus communication is possible via the onboard RS232 interface.

Please refer to the MVCweb – Installation & Commissioning Instructions (Product Literature No.: EN1B-0567GE51) for details.

Panel Bus

Optionally, one or both of the onboard RS485 interfaces can be used for Panel Bus communication with Honeywell Panel Bus I/O modules.

HTTP

MVCweb provides two operating options:

- Internet browsers having a resolution of 800x600 pixels or higher. Operation has been optimized for I.E. (9.0.x) and Mozilla Firefox® (15.0.x).
- Internet Explorer for WIN CE with resolution of 320x240 pixel, optimized for Excel Touch or other 5.7" touch panels.

For Internet Browser settings, please consult the Software Release Bulletin.

FTP

The firmware and application are downloaded using CARE via the standard FTP (File Transfer Protocol). Via FTP, product or plant-related literature can be downloaded (without special tools) into MVCweb for later use.

SMTP

Simple Mail Transfer Protocol is used for e-mail alarming via network and Internet-DSL connection.

RPC

CARE uses the following ports for firmware downloading and application downloading: UDP111, TCP5000, and TCP5001.

Remote LonWorks Access

The remote network interface of MVCweb allows its FTT LONWORKS network to be accessed via the MVCweb's IP connection. TCP3830 port is used for this purpose.

BUS AND PORT CONNECTIONS

WARNING

Risk of electric shock or equipment damage!

- ▶ Do not touch any live parts in the cabinet!
- ▶ Disconnect the power supply before making connections to or removing connections from terminals of the MVCweb Controller or Panel Bus I/O modules.
- ▶ Do not reconnect the power supply until you have completed installation.
- ▶ It is prohibited to power the MVCweb Controller with the same transformer used to power other controllers or devices (e.g., the PW M-Bus Adapter).
- ▶ Observe the rules regarding electrostatic discharge.

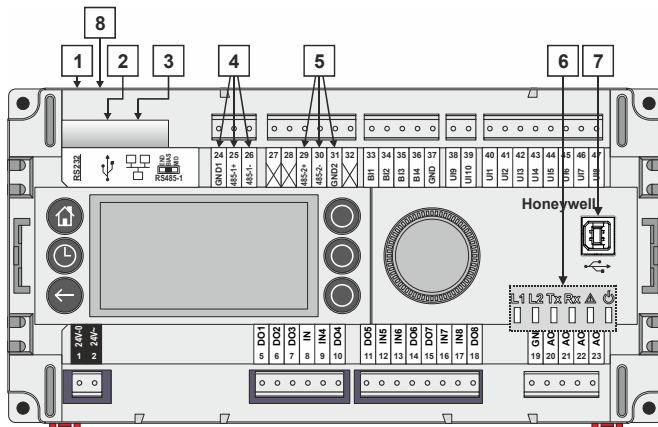

Fig. 2. Models with built-in HMI (top view)

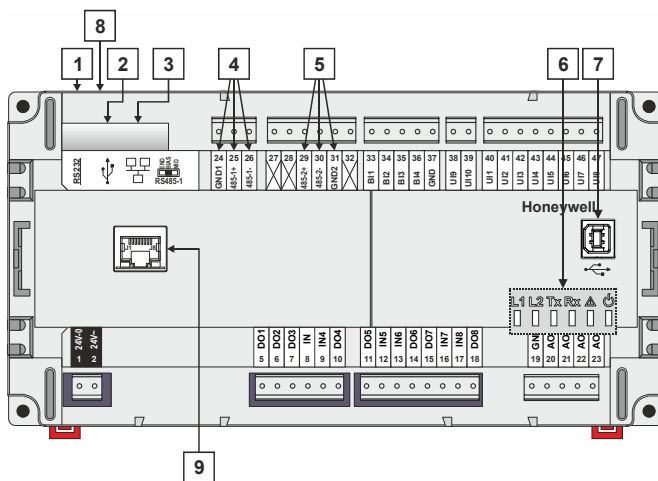

Fig. 3. Models without built-in HMI (top view)

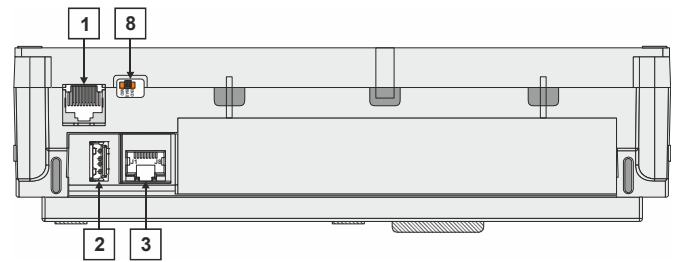

Fig. 4. All models (side view)

Legend

- 1 RS232 / RJ45 socket (for M-Bus connection and factory debugging)
- 2 USB 2.0 Host Interface (for connection of the IF-LON Interface); max. 500 mA, high speed
- 3 Ethernet / RJ45 socket (for BACnet IP communication); 10/100 Mbit/s; 1 "activity" LED
- 4 RS485-1 (isolated; for BACnet MS/TP, Panel Bus, or Modbus RTU Master communication*)
- 5 RS485-2 (non-isolated; for BACnet MS/TP, Panel Bus, or Modbus RTU Master communication*)
- 6 LEDs
- 7 USB 2.0 Device Interface (for connection to CARE / XW-Online and web browsers, Excel Touch, or other 3rd-party touch panels)
- 8 Three-position slide switch (for setting bias and termination resistance of RS485-1)
- 9 RJ45 socket for connection of MVC-2000HMI-A External HMI (for the MVC-WEB-2026B3A, only)

* Modbus RTU Master communication is possible on either one of the two RS485 interfaces, but not on both of them concurrently.

WARNING

Risk of electric shock or equipment damage!

- ▶ It is prohibited to connect any of the RJ45 sockets of the MVCweb Controller to a so-called PoE-enabled device ("Power over Ethernet").

M-Bus Connection

The MVCweb Controller can function as an M-Bus Master controller. It uses standard PW3/PW20/PW60 converters to connect to the M-Bus devices.

Wiring Topology

Max. bus length is 350 meters.

M-Bus devices are connected to the bus cable in parallel.

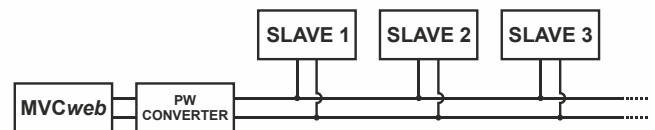

Fig. 5. Allowed M-Bus wiring topology

Cables

See section "M-Bus Connection" in MVCweb Controller – Installation & Commissioning Instructions (EN1B-0567GE51). Use shielded, twisted pair cable J-Y-(St)-Y 2 x 2 x 0,8.

Shielding

Shielding is especially recommended when the M-Bus cable is installed in areas with expected or actual electromagnetic noise. Avoiding such areas is to be preferred.

Use shielded, twisted pair cable J-Y-(St)-Y 2 x 2 x 0,8 and connect the shield to a noise-free earth ground – only once per M-Bus connection.

M-Bus Repeaters

The M-Bus can be extended to 1,000 meters, depending on the baud rate, and provided that the electrical limitations are observed. For details refer to the MVCweb - Installation & Commissioning Instructions (EN1B-0567GE51).

For bus length extension, M-Bus repeaters can be used, but have not been tested by Honeywell. Hence, it is the responsibility of the installing / commissioning personnel to ensure proper functioning.

M-Bus Master Specifications

Physical Layer

RS232 to PW3/PW20/PW60

Physical connector: RS232 / RJ45 socket (see Fig. 4)

Cable order number: XW586

Communication rates: 300, 2,400, and 9,600 Baud are supported, individually per M-Bus slave.

Max. no. of devices: 60 (excluding the MVCweb Controller)

Cable and wiring specifications: See MVCweb – Installation Instructions (EN1B-0567GE51).

Address Range

M-Bus slaves can have a primary address between 1 and 250.

Measurement Cycle

Individually per M-Bus slave, the measurement cycle can be configured from 1 to 604,800 sec (i.e., 1 second to 7 days).

M-Bus Communication Failure Indication

As soon as the MVCweb runs an application which includes M-Bus points, it will try to communicate with the M-Bus devices.

If an M-Bus slave does not respond to a message from the MVCweb Controller, the MVCweb Controller will repeat the message several times. If the M-Bus slave still does not respond, the MVCweb will stall the messaging to this M-Bus slave for 60 seconds. After these 60 seconds, the MVCweb Controller will again address the M-Bus slave. This cycle will be repeated endlessly as long as there is no answer.

If the MVCweb does not receive any response for ≥ 5 minutes, the mapped datapoint will go to the communication failure condition.

M-Bus "Unreliable_Other" Indication

Each M-Bus device has a status with 8 bits. The following bits are used to set all mapped datapoints from this M-Bus device to the "Unreliable_Other" condition.

Table 1. Bits used to set all mapped datapoints

Bit	Meaning	Result
0	app.-specific	ignored
1	app.-specific	ignored
2	low power	reliability flag set to Unreliable_Other
3	perm. error	reliability flag set to Unreliable_Other
4	temp. error	reliability flag set to Unreliable_Other
5	manuf.-spec.	ignored
6	manuf.-spec.	ignored
7	manuf.-spec.	ignored

Additionally, each data record has a function field which can indicate the data as "Value with Error." In this case, the corresponding datapoint (not all datapoints) is set to the "Unreliable_Other" condition.

NOTE: The "Unreliable_Other" condition will result in the corresponding datapoint value being set to the last valid value. This means that the value from the M-Bus device is not shown in the datapoint; rather, an old value is shown.

Open Source Library for M-Bus

The libmbus library is a component of RaditexSCADA that is published as open source, and it is free for anyone to use as long as due credit is given to RaditexSCADA and Raditex Control in derivative work based on the libmbus library.

Copyright (c) 2010-2011, Raditex Control AB. All rights reserved.

Redistribution and use in source and binary forms, with or without modification, are permitted provided that the following conditions are met:

- Redistributions of source code must retain the above copyright notice, this list of conditions, and the following disclaimer.
- Redistributions in binary form must reproduce the above copyright notice, this list of conditions, and the following disclaimer in the documentation and/or other materials provided with the distribution.
- Neither the name of the Raditex Control AB nor the names of its contributors may be used to endorse or promote products derived from this software without specific prior written permission.

THIS SOFTWARE IS PROVIDED BY THE COPYRIGHT HOLDERS AND CONTRIBUTORS "AS IS," AND ANY EXPRESS OR IMPLIED WARRANTIES, INCLUDING, BUT NOT LIMITED TO, THE IMPLIED WARRANTIES OF MERCHANTABILITY AND FITNESS FOR A PARTICULAR PURPOSE ARE DISCLAIMED. IN NO EVENT SHALL THE COPYRIGHT HOLDER OR CONTRIBUTORS BE LIABLE FOR ANY DIRECT, INDIRECT, INCIDENTAL, SPECIAL, EXEMPLARY, OR CONSEQUENTIAL DAMAGES (INCLUDING, BUT NOT LIMITED TO, PROCUREMENT OF SUBSTITUTE GOODS OR SERVICES; LOSS OF USE, DATA, OR PROFITS; OR BUSINESS INTERRUPTION) HOWEVER CAUSED AND ON ANY THEORY OF LIABILITY, WHETHER IN CONTRACT, STRICT LIABILITY, OR TORT (INCLUDING NEGLIGENCE OR OTHERWISE) ARISING IN ANY WAY OUT OF THE USE OF THIS SOFTWARE, EVEN IF ADVISED OF THE POSSIBILITY OF SUCH DAMAGE.

Modbus Connection

The MVCweb Controller can function as a Modbus Master. In general, the RS485 wiring rules must be followed.

Wiring Topology

Only daisy-chain wiring topology is allowed. Short derivation ("stub") cables (with a max. length of 20 m) from the "trunk cable" to the Modbus devices are allowed.

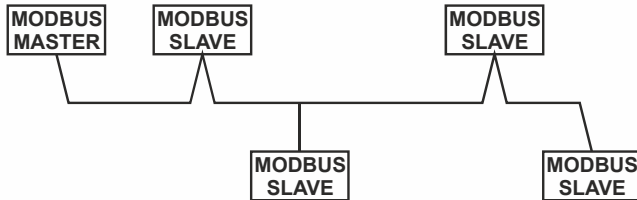

Fig. 6. Allowed Modbus wiring topology

Other wiring topologies (e.g., star wiring, or mixed star wiring and daisy chain wiring) are prohibited; this is to avoid communication problems of the physical layer.

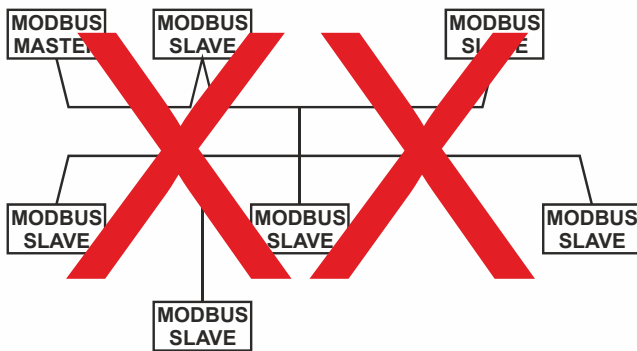

Fig. 7. Prohibited Modbus wiring topology (example)

Cables

See section "EIA 485 Cable Specifications" in MVCweb Controller – Installation & Commissioning Instructions (EN1B-0567GE51).

Use shielded, twisted pair cable J-Y-(St)-Y 2 x 2 x 0,8.

You **must** use three wires:

- One wire for D1 = Modbus +
- One wire for D0 = Modbus –
- One wire for the signal common

When using one pair for D1 and D0 and one wire of another pair for the signal common, CAT5 cable may also be used.

For connection details, see MVCweb Controller – Installation & Commissioning Instructions (EN1B-0567GE51).

Shielding

Shielding is especially recommended when the Modbus cable is installed in areas with expected or actual electromagnetic noise. Avoiding such areas is to be preferred.

Use shielded, twisted pair cable J-Y-(St)-Y 2 x 2 x 0,8 and connect the shield to a noise-free earth ground – only once per Modbus connection.

RS485 Repeaters

RS485 repeaters are possible, but have not been tested by Honeywell. Hence, it is the responsibility of the installing / commissioning personnel to ensure proper functioning.

NOTE: Each Modbus segment requires its own line polarization and line termination.

Modbus Master Specifications

Modbus Compliance

As per the Modbus standard, the MVCweb Controller is a conditionally compliant "regular" Modbus device. The MVCweb Controller differs from an unconditionally compliant "regular" Modbus device in that it does not support communication rates of 1.2, 2.4, and 4.8 kBaud (because these communication rates are not market-relevant).

Physical Layer

2-wire serial line RS485 (EIA-485) (with additional common)
 Communication rates: 9.6, 19.2, 38.4, 57.6, 76.8, and 115.2 kBaud supported.

Max. number of devices: 32

Cable and wiring specifications: See MVCweb Controller – Installation & Commissioning Instructions (EN1B-0567GE51).

Communication Mode

Modbus Master.

Transmission Mode

RTU (Remote Terminal Unit)

Address Range

Modbus slaves can have an address between 1 and 247. Discrete Inputs, Coils, Input Registers and Holding Registers can have an address between 1 and 9999.

Function Codes

The following function codes are supported:

Table 2. Supported function codes

function code (hex)	function
02	Read Discrete Inputs
01	Read Coils
05	Write Single Coil
04	Read Input Register
03	Read Holding Register
06	Write Single Register
10	Write Multiple Registers

Exception Codes

Upon reception of any of the following exception codes, datapoints of the MVCweb application will show "no response."

Table 3. Supported exception codes

exception code (hex)	function
01	illegal function
02	illegal data address
03	illegal data value
04	slave device failure
05	acknowledge
06	slave device busy

Register Sizes

The following Register sizes are supported:

- 16-bit Registers for Discrete inputs, Coils, Input Registers, and Holding Registers
- 32-bit Registers for Input Registers and Holding Registers.

Data Types

The following data types are supported:

- Discrete Inputs:
 - BOOL
- Coils:
 - BOOL
- Input Registers:
 - BOOL
 - INT16, UINT16
 - INT32, UINT32
 - FLOAT
- Holding Registers:
 - BOOL
 - INT16, UINT16
 - INT32, UINT32
 - FLOAT
 - 32-bit floating points can be transmitted as two consecutive 16-bit registers.

Byte and Word Order Transmission

- Most Significant Byte First (default)
- Lower Significant Byte First
- Most Significant Word first (default)
- Lower Significant Word first

Bit Unpack

The MVCweb allows direct reading of single bits of an Input Register or of a Holding Register into a data-point.

In typical situations in which several different status bits of a Modbus slave's Register need to be read and linked into the MVCweb application, this allows for very efficient application engineering.

Number of Stop Bits

One and two stop bits are supported.

Error Checking Mode

Parity checking: No parity, even parity, odd parity.

Frame checking: Cyclical redundancy checking (CRC).

Life Check of Modbus Slaves

The MVCweb checks the Modbus every 15 seconds for lost Modbus slaves.

Message Response Timeout

20 msec ... 5000 msec.

Modbus Slaves Measurement Cycle

The measurement cycle of all addressable Modbus slaves depends upon the number of connected Modbus slaves and the total number of mapped datapoints. The minimum measurement cycle is 500 msec. This cycle time is based upon the read cycle of the datapoint manager in the firmware.

Modbus Communication Failure Indication

As soon as the MVCweb runs an application which includes Modbus points, it will try to communicate with the Modbus devices based on the Modbus to datapoint mapping of the application.

If a Modbus slave does not respond to a message from the MVCweb controller, the MVCweb controller will repeat the message two times. If the Modbus slave does not respond to the two message repeats either, the MVCweb will stall the messaging to this Modbus slave for 15 seconds. After these 15 seconds, the MVCweb controller will again address the Modbus slave with the same two repeats, if necessary. This cycle will be repeated endlessly.

**WARNING****NETWORK SECURITY**

Honeywell hereby expressly states that the MVCweb controller is not inherently protected against cyber attacks from the Internet and that it is therefore intended solely for use in private, protected networks.

Unprotected Internet connections can expose the MVCweb controller to cyber attacks from third parties who can then damage it and connected facility components or cause them to malfunction, or who can misuse it for illegal purposes for which the operator may then be held liable.

When directly connected to the Internet, the MVCweb controller automatically becomes a potential target for cyber attacks. Corresponding protective measures are therefore essential if safe and reliable operation is to be ensured. If it is not necessary for the MVCweb controller to be accessible from the Internet, it should be isolated from the Internet via a suitable firewall.

If it is necessary for the MVCweb controller to be accessible from the Internet (e.g., in order to perform remote maintenance), the use of a coded VPN connection is indispensable. Suitable VPN routers are available from numerous third-party manufacturers in a wide variety of designs, for operation at 230 V or 24 V.

For details, see also MVCweb Networking Whitepaper (Product Literature No.: EN2B-0398GE51).

CONTROLLER SPECIFICATIONS

Table 4. Controller specifications

Ambient temperature	0 ... 40 °C (wall-mounting) 0 ... 50 °C (cabinet/door mounting)
Storage temperature	-20 ... +70 °C
Humidity	5 ... 95% r.h. non-condensing
Dimensions	See Fig. 9 and Fig. 10.
Degree of protection	IP20 (mounted on walls, with two accessory MVC-80-AC1 covers) IP30 (mounted in cabinet doors, with accessory MVC-80-AC2)
Fire class	V0
Shock protection	Class II
Pollution degree	2
Installation	Class 3
Rated impulse voltage	300 V for SELV, 2500 V for relay outputs
Automatic action	Type 1.C
Software class	Class A
Ball-pressure test temperature	housing parts >75°C terminals >125°C

Electrical Data

Table 5. Electrical data

Power supply	19 ... 29 VAC, 50/60 Hz, or 20 ... 30 VDC
Power consumption	typically dc: 5 W; max. 6 W typically ac: 9 VA; max. 11 VA
Current consumption	typically dc: 210 mA; max. 240 mA typically ac: 370 mA; max. 410 mA

MVCweb and 24 Vac field devices can obtain their power from the same transformer.

Mechanical Data

Housing Dimensions (L x B x T): 215.5 x 110 x 61 mm

Housing Material: ABS blend; flame retardant V0

Weight: 0.6 kg (without packaging)

Protection Class: IP 20

CPU

Processor

- ARM 9 32-bit processor, 450 MHz

Operating System: LINUX

Memory

- 128 MB DDR2-RAM
- 1 GB Flash Memory

Real-Time Clock

- accuracy: ± 2 minutes per year (at, typically, 25 °C)
- buffered typically for 72 h by gold capacitor

Standards, Approvals, etc.

- Device meets BTL, AMEV AS-A, EN 60730-1, EN 60730-2-9, UL60730, and UL916.
- Refer to Code of Practice standards IEC 61000-5-1 and -2 for guidance.
- The device complies with Ethernet Protocol versions IEEE 802.3.
- The device supports BACnet IP and BACnet MS/TP communications as per ANSI / ASHRAE 135-2010.

MMI

The XL2014B2B, XL2026B2A, and XL2000B2A incorporate a user interface (HMI) featuring the following components:

- one LCD Display (1);
- six operating keys (2);
- one Rotate&Push Button (3); and
- six LEDs (4)

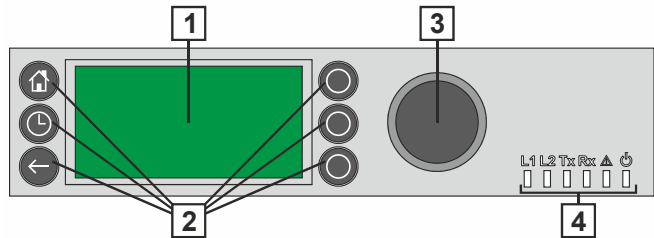

Fig. 8. MVCweb Controller user interface (HMI)

The LCD display is the graphic interface presenting items for application-specific system information, operator entries, and menus of functions. The LCD display can show max. five lines of alphanumeric text with max. 20 characters per line.

The backlight of the LCD is switched on once an operating key or the rotate&push button is pressed. The backlight is switched off if any of the operating keys or the button are not used for 2 minutes.

The six operating keys consist of three fixed-function keys (left) and three soft keys (right).

The Rotate&Push button is used to navigate through menus and lists; to highlight items (menu, list, option, value, command symbol), and to adjust options (ON, OFF, etc.) and values (temperature in °C, etc.).





Mounting

The MVCweb Controller is suitable for mounting as follows:

- ▶ in cabinets;
- ▶ in fuse boxes conforming with standard DIN43880, and having a slot height of max. 45 mm;
- ▶ on walls (using accessory MVC-80-AC1).
- ▶ in cabinet front doors (using accessory MVC-80-AC2);

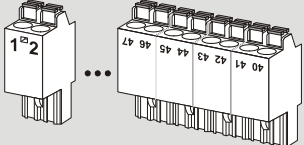
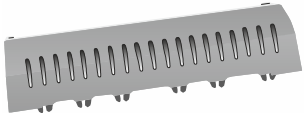
Extra Parts

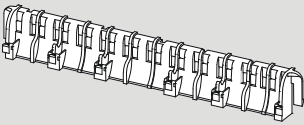
Table 6. Extra parts (not included in controller delivery package)

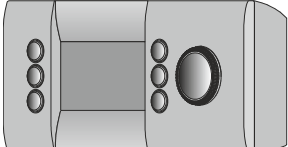
	order number	description
	TPU-45-01	Removable terminal plugs, push-in type; complete set of 9 plugs (for terminals 1 - 47); for the MVC-WEB-2014Bxx and MVC-WEB-2026Bxx.
	MVC-80-AC1	Terminal cover (color: RAL9011); package of 10; for MVCweb Controllers.
	MVC-80-AC2	Front door mounting accessory (color: RAL9011); package of 10; for MVCweb Controllers.
	MVC-40-AC3	Strain relief; package of ten; for MVCweb Controllers.
	XS830	Set of ten packages. Each Auxiliary Terminal Package consists of two groups of nine internally connected push-in terminals, for distributing signals / power. For the Mixed Panel Bus I/O Module and the MVCweb Controller, only. Please refer to Honeywell I/O Modules - Installation & Commissioning Instructions (EN1B-0556GE51) for more information.
	XS831	Set of ten packages. Each Auxiliary Terminal Package consists of two groups of four pairs of push-in terminals (each with a 499 Ω resistor), for converting 0...20 mA signals into 0...10 VDC signals, and one push-in ground terminal per group. Please refer to Honeywell I/O Modules - Installation & Commissioning Instructions (EN1B-0556GE51) for more information.
	MVC-2000HMI-A	External HMI with LCD display which derives needed electrical energy from the MVCweb controller. Suitable for connection to the RJ45 socket on the front of the MVC-WEB-2026B3A.

MODELS

- MVC-WEB-2014B2B(with HMI, 14 onboard I/Os, and 52 I/Os in total*; MVC-2000HMI-A External HMI cannot be connected)
- MVC-WEB-2026B2A (with HMI, 26 onboard I/Os, and 600 I/Os in total*; MVC-2000HMI-A External HMI cannot be connected)
- MVC-WEB-2026B3A (with 26 onboard I/Os and 600 I/Os in total*; with RJ45 socket for connection of MVC-2000HMI-A External HMI)

*I/Os in total include onboard I/Os, I/Os via Panel Bus, and I/Os via LONWORKS Bus.

Table 7. Overview of models

feature	description	max. cable length	order no.			
			MVC-WEB-2014B2B	MVC-WEB-2026B2A	MVC-WEB-2026B3A	
UI	NTC20kΩ / 0...10V / slow BI	400 m	4	8	8	
	NTC20kΩ / 0...10V fix pull-up / slow BI	400 m	-	2	2	
BI	open = 24 V / closed 2.0 mA / totalizer 15 Hz	400 m	4	4	4	
AO	0..11 V (max. 1 mA)	400 m	2	4	4	
BO	Relay N.O. contact	400 m	3	4	4	
	Relay N.O. contact (high in-rush)	400 m	1	1	1	
	Relay N.O. contact with one common	400 m	-	3	3	
bus interfaces	RS485-1, isolated, BACnet MS/TP, Panel Bus, or Modbus RTU Master communication	*1000 m	1	1	1	
	RS485-2, non-isolated, BACnet MS/TP, Panel Bus, or Modbus RTU Master communication	*1000 m	1	1	1	
	Ethernet / RJ45 socket	e-mail communication, browser access	100 m	1	1	1
		BACnet IP communication	100 m	1	1	1
	USB 2.0 Device Interface (as Network Interface)	3 m	1	1	1	
	USB 2.0 Host Interface (max. 500 mA)	3 m	1	1	1	
	RS232 M-Bus communication via PW3 / PW20 / PW60 converters	*350 m	1	1	1	
user interface	HMI with graphic LCD	--	X	X	-	
	Fast Access buttons	--	6	6	-	
	push and turn button	--	1	1	-	
HMI	power LED (green)	--	1	1	1	
	status LED (red, controllable by firmware)	--	1	1	1	
	applications-specific LED L1 (yellow)	--	1	1	1	
	USB LED L2 (yellow)	--	1	1	1	
	bus status LEDs (for isolated RS485-1 interface)	--	2	2	2	
HMI socket	RJ45 socket for connection of MVC-2000HMI-A External HMI	5 m	--	--	X	

* Depending upon baud rate. For max. cable lengths, see MVCweb – Installation & Commissioning Instructions (Product Literature No.: EN1B-0567GE51).

DIMENSIONS

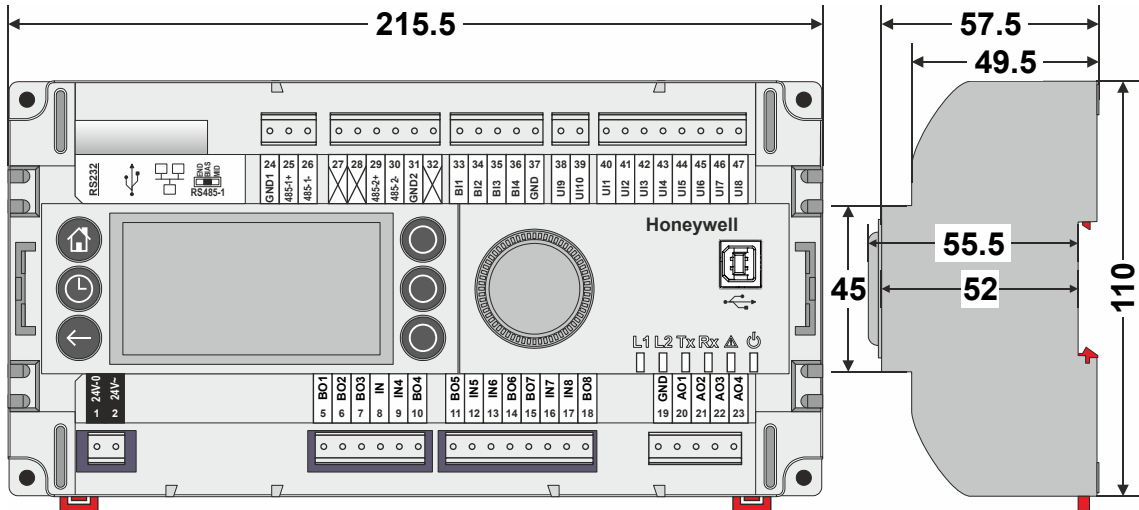

Fig. 9. MVCweb Controller with built-in HMI, dimensions (in mm)

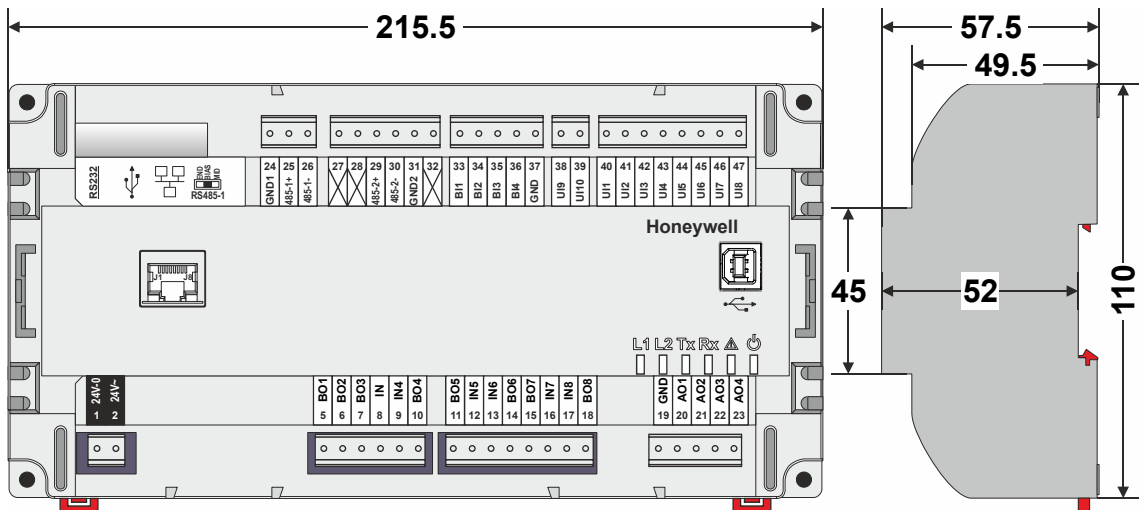

Fig. 10. MVCweb Controller with RJ45 socket for connection of MVC-2000HMI-A External HMI, dimensions (in mm)

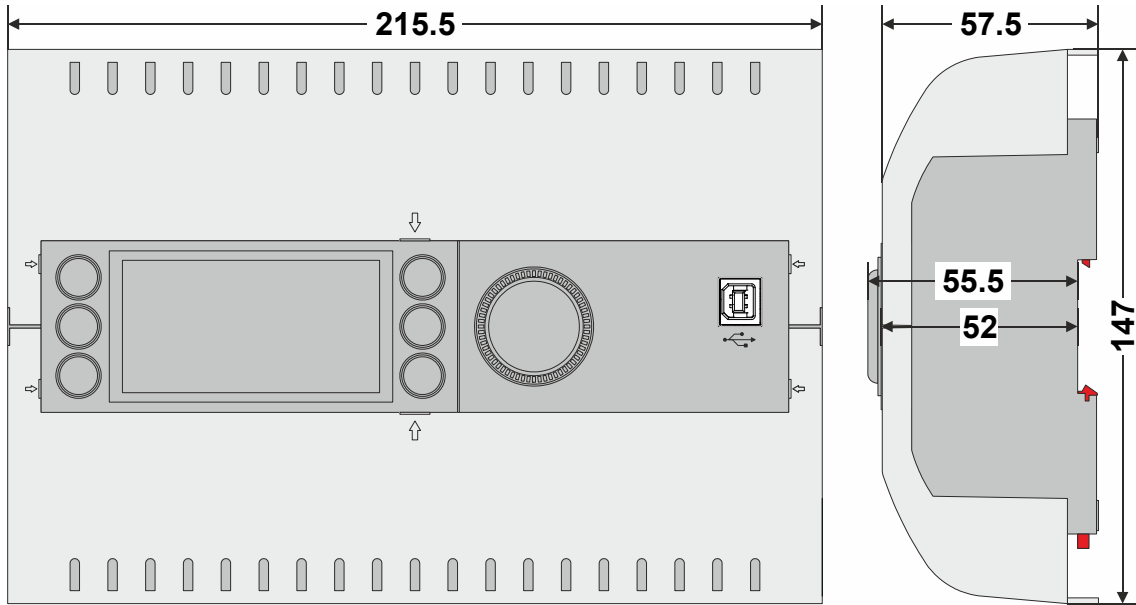

Fig. 11. MVCweb Controller with built-in HMI (with MVC-80-AC1), dimensions (in mm)

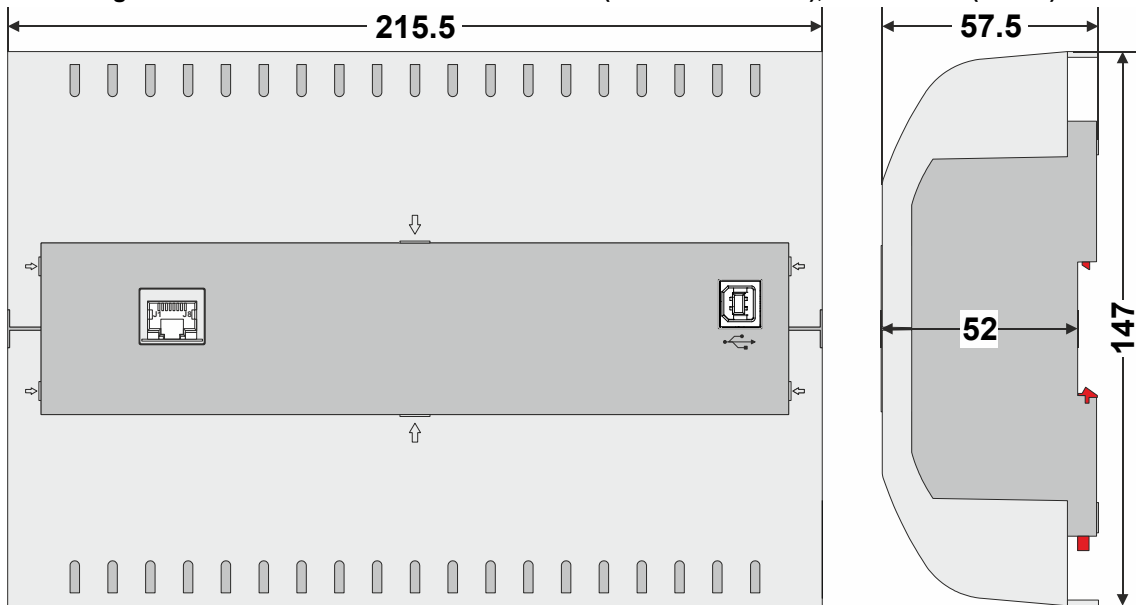

Fig. 12. MVCweb Controller with RJ45 socket for MVC-2000HMI-A External HMI (with MVC-80-AC1), dimensions (in mm)

NOTE: Use of the covers (MVC-80-AC1) will obstruct access to the Ethernet and USB 2.0 Host Interfaces

Honeywell

Manufactured for and on behalf of the Environmental and Combustion Controls Division of Honeywell Technologies Sàrl, Rolle, Z.A. La Pièce 16, Switzerland by its Authorized Representative:

Automation and Control Solutions

Honeywell GmbH
 Böblinger Strasse 17
 71101 Schönaich, Germany
 Phone +49 (0) 7031 637 01
 Fax +49 (0) 7031 637 740
<http://ecc.emea.honeywell.com>

EN0B-0713GE51 R0514

Subject to change without notice